



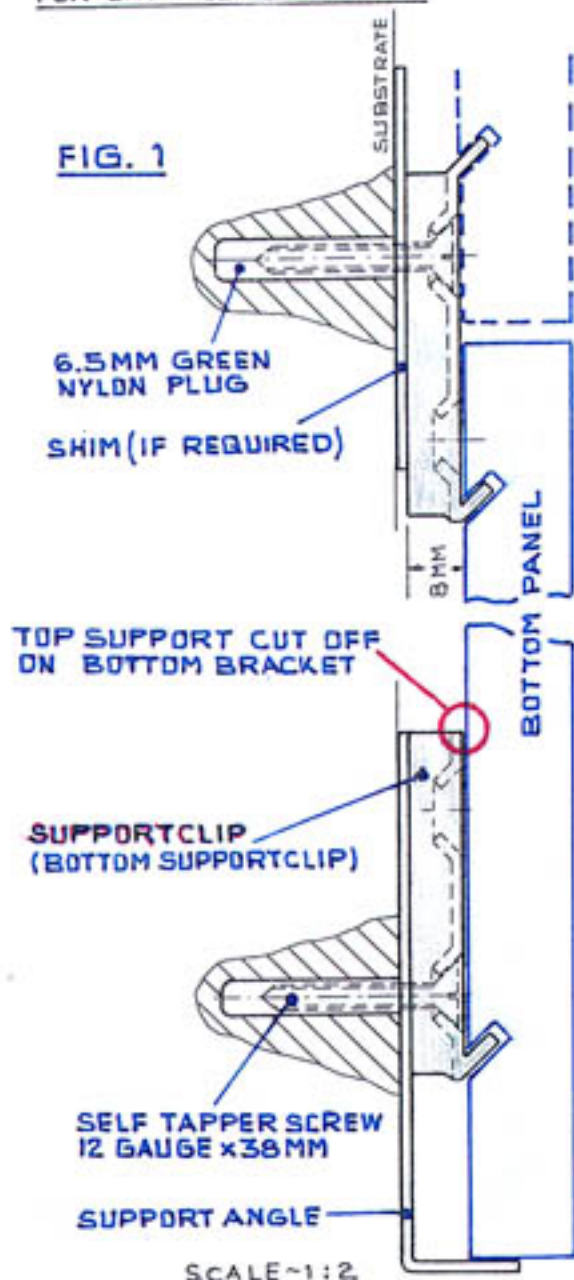
SUPPORTCLIP

THIN PANEL CLADDING

SUPPORTCLIP CAN BE USED FOR CAVITIES OF 8MM TO 12MM STRAIGHT INTO THE SUBSTRATE (FIG. 1 AND 3). SUPPORTCLIP CAN ALSO BE USED ON A RAILS SYSTEM UNISTRUT. A CAVITY OF APPROXIMATELY 40MM IS POSSIBLE USING UNISTRUT CHANNEL 41MM x 21MM AS SHOWN IN FIG. 2. WITH VERY ACCURATELY MOUNTED CHANNELS, SUPPORTCLIP MAY BE POSITIONED - USING BACKING PLATE - DIRECTLY AGAINST THE CHANNEL, FIG. 2 AND 4. IF COMBINING UNISTRUT 41x21 AGAINST UNISTRUT 41x41 A CAVITY OF 75MM IS ACHIEVABLE, FACILITATING PLACEMENT OF INSULATION, FIG. 4.

SLIMLINE SUPPORTCLIP: TILE INSTALLATION HAS TRADITIONALLY BEEN DONE WITH CEMENT-BASED ADHESIVE FIX. ADHESIVE/GLUE MAY RELEASE FROM TILE OR SUBSTRATE DUE TO HEATING/COOLING, WET/DRY EFFECTS OF WEATHER OR UNCLEAN TILE/SUBSTRATE SURFACE. HERE "SLIMLINE" SUPPORTCLIP (FIG. 3) WILL PROVIDE ADDED SECURITY AGAINST PANEL FAILURE ON BUILDINGS. SLIMLINE SUPPORTCLIP IS USED WITH ADHESIVE/GLUE (BETWEEN SUBSTRATE AND CLIP), EG. SIKAFLEX 11 FC (HIGHSTRENGTH POLYURETHANE FORMULA ADHESIVE SEALANT) OR POWERS AC 100 E (POLYESTER INJECTION SYSTEM). FOR ADJUSTMENT ON UNEVEN SUBSTRATE SHIMS MAY BE USED.

FOR CAVITIES 8 TO 12 MM

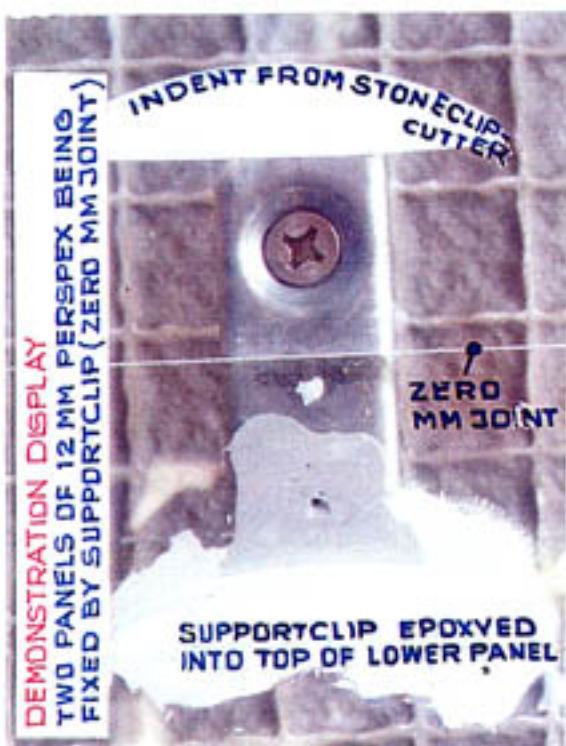
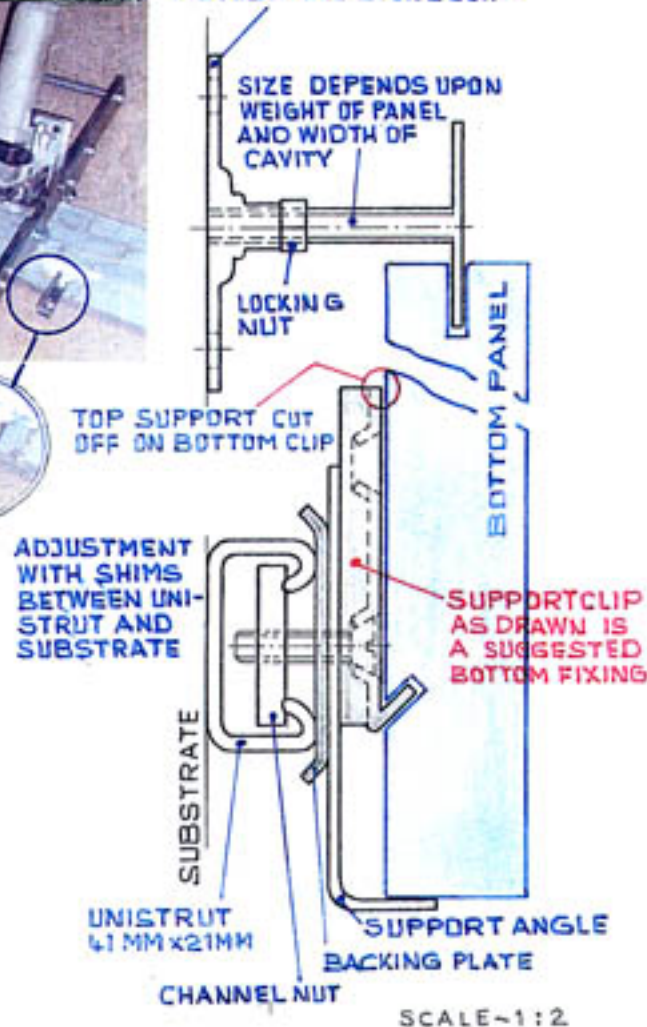


HOW TO INSTALL SUPPORTCLIP AS MECHANICAL FIXING

- 1 ALL FIXING POINTS (SLOTS) ON PANELS ARE TO BE CUT PRIOR TO INSTALLATION, USING STONECLIP-CUTTER (SEE PHOTO).
- 2 SUPPORTCLIPS ARE TO BE EPOXYED INTO TOP FIXING POINTS OF THE PANELS. THE EPOXY SHOULD BE LEFT TO CURE BEFORE FIXING PANELS TO SUBSTRATE/CHANNEL.
- 3 FIX BOTTOM SUPPORTCLIPS TO PRE-DETERMINED POSITIONS ON SUBSTRATE OR CHANNEL. BOTTOM SLOTS OF PANEL ARE TO BE FILLED WITH EPOXY AND PANEL IMMEDIATELY MOUNTED ONTO (BOTTOM-) SUPPORTCLIPS AND...
- 4 TOP SUPPORTCLIPS SECURED AGAINST SUBSTRATE OR UNISTRUT.
- 5 MARKINGS ON THE STONECLIP-CUTTER ALLOW FOR JOINTS OF 0MM, 1.5MM, 3MM OR 6MM TO BE LAID.
- 6 THIS SYSTEM IS OF GREAT BENEFIT WHEN WORKING WITH PANELS UP TO 1200MM x 600MM x 13MM, WEIGHING UP TO 30 KGS.
- 7 SINCE THE TOP BRACKETS OF A PANEL, NOT ONLY FIX/SECURE THE PANEL BUT ALSO TAKE IT'S WEIGHT, ONE DOESN'T HAVE TO WORRY ABOUT GLUE OR EPOXY (IN BOTTOM FIXING POINTS) TO SET OR CURE BEFORE INSTALLING THE NEXT COURSE IF A SPACER IS INSERTED, E.G. 3MM.

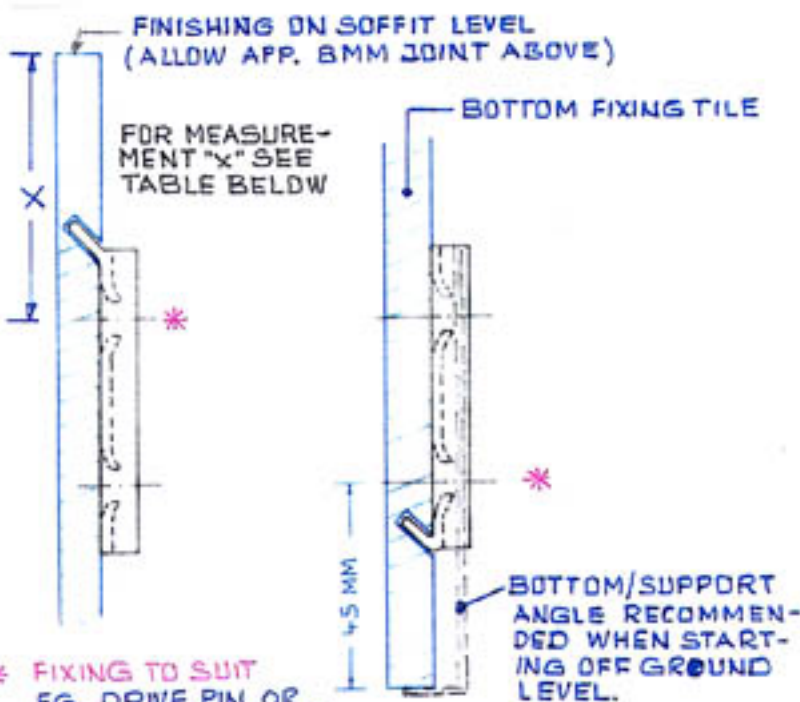


FIG. 2 ADJUSTABLE STONECLIP



DISTANCE "X" MM	59	57	55	etc.
CUTTER SET FOR JOINT... MM	0.5	1.5	3	

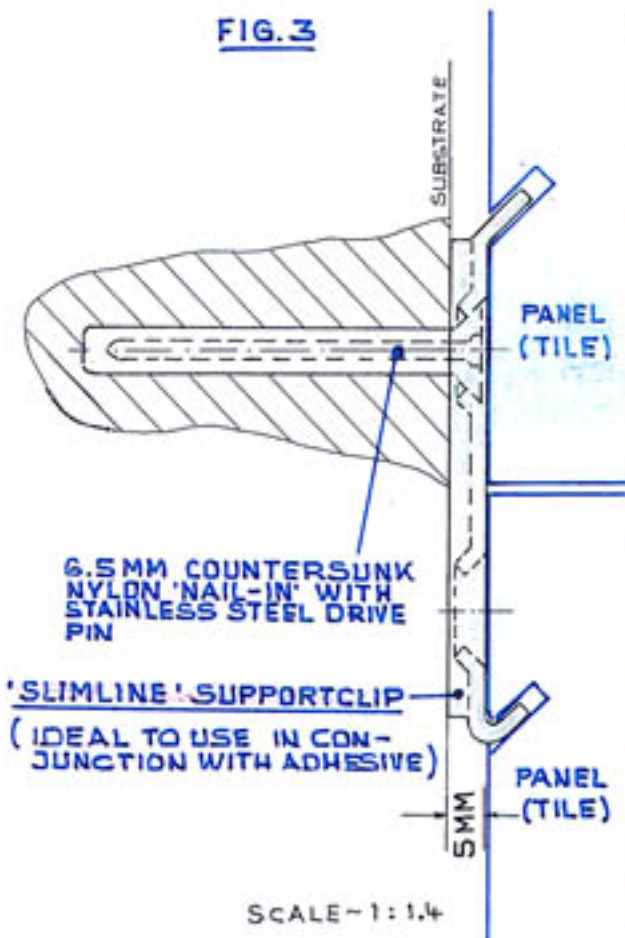
- 8 TO ACHIEVE A PLUMB (PANEL-) SURFACE, PLASTIC GLASS SHIM ADJUSTERS (FROM 0.5MM TO 6MM) MAY BE USED. LEAST NUMBERS OF SHIMS TO BE PREFERRED (E.G. USE 1x3MM SHIM INSTEAD OF 2x1.5MM SHIMS). IF SOME PANELS DIFFER IN THICKNESS (ARE THINNER) ABOVE MENTIONED SHIM MAY ALSO BE EPOXYED ONTO THE BACK OF THE PANEL ABOVE WHERE THE CLIP ENTERS THE PANEL.



* FIXING TO SUIT EG. DRIVE PIN OR PLUG AND SCREW

NOTE: SLOTS ARE USUALLY CUT 100MM FROM (VERTICAL) EDGE.

FIG. 3



SUPPORT CLIP DESIGN CAPACITY.

The following table is for the Support Clip carrying vertical loading and lateral loading. Each Clip is fixed with one countersunk 14 gauge screw through one of the two holes in the Clip plate. Fixings are to be selected in accordance with fixing manufacturer's documentation.

Max Vertical Load per Clip [kg]	Max Wind Area #) [m ²]	Fixing loading	
		Shear *) [kN]	Tension *) [kN]
25 ^)	0.25 ^)	0.35	0.70

#) The wind area is the maximum area that one Support Clip can resist based on the design wind pressure of 2.53 kPa, as noted in the design assumptions. For other wind loading situations engineered solutions based on the above tension capacity may provide increased/reduced wind areas.

*) Limit State Load

^) Subject to fixing hole pull through capacity testing

CERTIFICATION

The pull through capacity of the hole in the clip for the screw has yet to be determined through load testing and the pull through capacity of the hole is therefore not part of this certification.

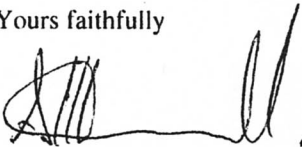
If the Support Clip installation is completed in accordance with the above design, the Stoneclip.com specifications and sound building practice, and provided that load testing can prove that the tension capacity of the hole is adequate, then the "Support Clip" mechanical fixing is considered to be structurally adequate.

This certificate does not cover the strength of the Tile Panel or the transfer of load from the Tile Panel to the Support Clip.

The certificate does not cover the fixing or the substrate to which the clip is attached. Proprietary fixings to the substrate are to be selected based on the strength limit state loading given in the above table and based on the design capacities provided by the manufacturer of the fixing.

The undersigned is a Registered Practising Engineer in Queensland (RPEQ No. 8023)

Yours faithfully



S McDonald
for and on behalf of
SHEEHY & PARTNERS PTY LTD
Consulting Engineers

