

SM:/GA7142.003

Page 1 of 2

December 2007

**SHEEHY &  
PARTNERS**  
PTY LIMITED  
CONSULTING ENGINEERS  
STRUCTURAL AND CIVIL  
A.C.N. 009 899 905  
A.B.N. 52 009 899 905

**TO WHOM IT MAY CONCERN**

**STONECLIP.COM “UNI-STRUT STONECLIP”**

This is to certify that Sheehy & Partners have checked the design of the mechanical fixing known as “Uni-Strut StoneClip”. The Uni-Strut StoneClip parameters and design capacities are summarised below.

**DESIGN ASSUMPTIONS**

The design has been based on the following:

- Uni-Strut StoneClip samples provided to this office.
- All components of the clip have been designed in accordance with AS 4673:2001- “Cold-Formed Stainless Steel Structures”, AS4600:1996 “Cold-Formed Steel Structures”, other relevant codes, and in accordance with widely accepted engineering principles.
- The load factor applied to Panel Dead Loads is 1.35 for Dead load only in accordance with AS1170.0:2002 “Structural Design Actions”. When combined with wind loading a Dead Load factor of 1.2 is used.
- Where Uni-Strut StoneClips are to resist lateral loads they have been designed for a strength limit state pressure of 2.92 kPa. For lateral wind loadings, this is equivalent to buildings in wind region B and terrain category 2 and for a maximum cladding height of 10 m in accordance with AS1170-2:2002 “Structural design actions - Wind actions”.
- The Uni-Strut used has a steel thickness of 2.5 mm.

**UNI-STRUT STONE CLIP GEOMETRY**

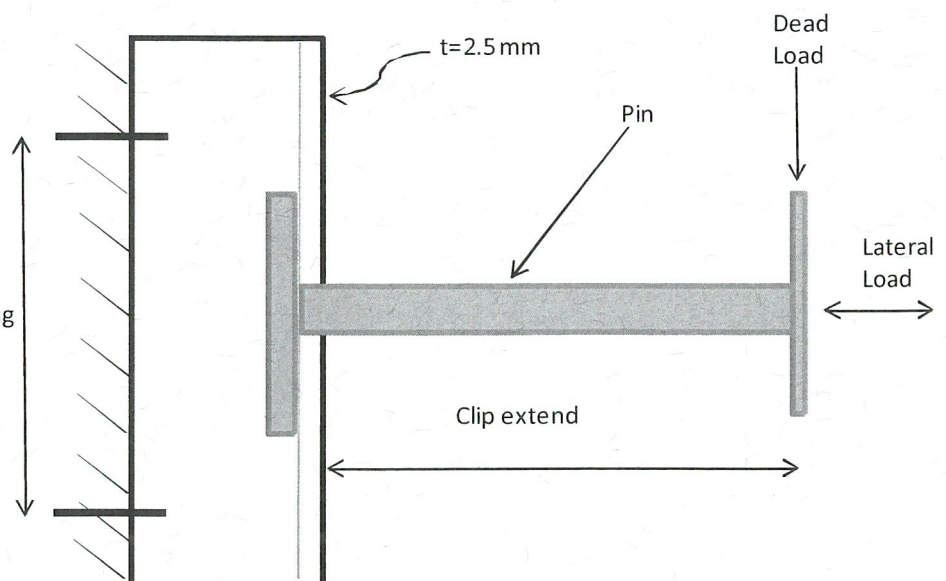

**DIRECTORS:**

P. Cockerill,  
Cert.Eng.

S. Thomas,  
B.Eng.(Hons), M.I.E.Aust.

S. McDonald,  
B.Eng. (Hons), M.I.E.Aust.  
MBA



3 Gregory Terrace  
SPRING HILL QLD 4000  
Phone: (07) 3839 3644  
Facsimile: (07) 3839 3655  
Email: mail@sheehy.com.au

### UNI-STRUT STONECLIP DESIGN CAPACITY TABLE

The following table is for Uni-Strut StoneClips carrying vertical and lateral loading. The Uni-Strut is fixed to the substrate in accordance with StoneClip.com's specifications at a maximum spacing of 500 mm c/c as indicated on the above sketch. Fixings are to be selected in accordance with fixing manufacturer's documentation.

Table 1.1 – Load Capacity – Uni-Strut StoneClip M12 pin on Uni-Strut

Clip extend*) [mm]	Max Vertical Load per Clip [kg]	Max Wind Area #) [m <sup>2</sup> ]
75	45.6	0.63
60	65.1	0.55
50	91.1	0.44

\*) The clip extend is the distance from the face of the Uni-Strut to the StoneClip disc.

#) The wind area is the maximum area that one Uni-Strut StoneClip can resist based on the design wind pressure of 2.92 kPa, as noted in the design assumptions. For other wind loading situations engineered solutions based on the above tension capacity may provide increased/reduced wind areas.

### CERTIFICATION

If the Uni-Strut StoneClip installation is completed in accordance with the above design, the Stoneclip.com specifications and sound building practice, the "Uni-Strut Stone-Clip" mechanical fixing is considered to be structurally adequate.

This certificate does not cover the strength of the stone panel or the transfer of load from the Stone Panel to the "Uni-Strut StoneClip".

This certificate does not cover the fixings connecting the Uni-Strut to the substrate or the substrate to which the Uni-Strut is attached.

The undersigned is a Registered Practising Engineer in Queensland (RPEQ No. 8023)

Yours faithfully

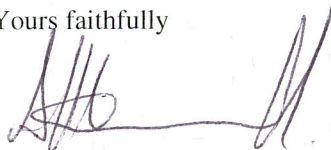

S McDonald  
for and on behalf of  
**SHEEHY & PARTNERS PTY LTD**  
Consulting Engineers